



### Nominal data

Type	8452/2 HHP	
Nominal voltage	VDC	12
Nominal voltage range	VDC	10,8 .. 13,2
Speed (rpm)	min <sup>-1</sup>	4400
Power consumption	W	3.5
Min. ambient temperature	°C	-20
Air flow	m <sup>3</sup> /h	83
Sound power level	B	5.5
Sound pressure level	dB(A)	42

ml = Max. load · me = Max. efficiency · fa = Free air · cs = Customer specification · ce = Customer equipment  
Subject to change

**Technical description**

<b>Weight</b>	0.105 kg
<b>Dimensions</b>	80 x 80 x 25 mm
<b>Impeller material</b>	Glass-fiber reinforced PA plastic
<b>Housing material</b>	Glass-fiber reinforced PBT plastic
<b>Part no.</b>	929507012
<b>Airflow direction</b>	Exhaust over struts
<b>Direction of rotation</b>	Counterclockwise, viewed toward rotor
<b>Bearing</b>	Ball bearing
<b>Service life L10 at 40 °C</b>	65000 h
<b>Service life L10 at maximum temperature</b>	40000 h
<b>Cable</b>	With leads AWG 24, TR 64

Product drawing

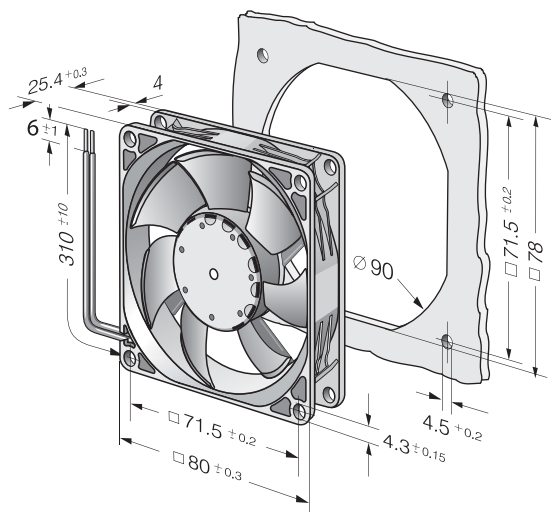

## Curves

